

# SMART3G-C2

## intrinsically safe detector

SMART3G-C2 gas detector is designed to meet industrial requirements; the enclosure is explosion proof and can be installed in ATEX Zone 1 and, when equipped with dust adapter, in Zone 21. To detect particular toxic gas, the sensing element must be directly exposed to the mixture. In this condition the protection mode is guaranteed by a galvanic separation of the electronics in the sensor head and in the enclosure. The galvanic separation fulfils the requirements for the intrinsically safe protection mode.

The sensing element is placed in the stainless steel head with a 48 mm diameter. The electrochemical cell is used to detect toxic gas, due to the optimal performance in these applications. The gas detector has a 12-24 Vdc power supply and a standard 4-20 mA 3-wires output. Optionally, the SMART3G-C2 can be equipped with serial RS485 communication and a 1 or 3 relays board.

The aluminium enclosure has dimensions 138 x 200 x 119 mm, with 3 cable entries 3/4" NPT threaded.

The gas detector can be ATEX marked as following:

CE 0722 Ex II 2G Ex db [ib] ib IIC T6 Gb

Or, when equipped with dust adapter:

CE 0722 Ex II 2GD Ex db [ib] ib IIC T6 Gb  
Ex tb IIIC T6 T85°C Db  
IP65

The gas detector is IECEx compliant and can be marked as following:

II 2G Ex db [ib] ib IIC T6 Gb

Or, when equipped with dust adapter:

II 2GD Ex db [ib] ib IIC T6 Gb  
Ex tb IIIC T6 T85°C Db  
IP65

SMART3G-C2 is SIL2 hardware and SIL3 software; with a redundant system also the hardware is SIL3.

### Sensor

Application	Industrial area, ATEX Zone 1 and Zone 21 (when equipped with dust adapter, optional)
Sensing element	Electrochemical cell
Predicted sensor lifetime	2 / 3 years
Gas detected	Sulphur dioxide [0-20 ppm] Nitrogen dioxide [0-20 ppm] Chlorine [0-5 ppm]; [0-20 ppm]

### Parametri elettrici

Power supply	12-24 Vdc
Output	Analogue 4-20 mA output; 1 or 3 relay board (optional); serial RS485 output (optional)
Maximum dissipated power	4.5 W
Relays contact ratings (optional board)	1.0 A a 30 Vdc
Optical indications	-
Acoustic indications	-
Hall effect sensor	-

### Environmental conditions

Storage temperature	0 / +20°C up to 6 months
Operating temperature	-20 / +50°C
Operating humidity	15 / 90% RH non condensing



### External case

Material	Enclosure: aluminium with epoxy paint chromating and chemically resistant Sensor head: stainless steel
Protection mode	Ex i : Intrinsically safe protection mode Ex t : Equipment dust ignition protection by enclosure (when equipped with dust adapter, optional)
Dimensions	138 x 200 x 119 mm
Weight	2700 g
Cable entries	3 x 3/4" NPT
IP grade	IP65

### Compliance

EMC	EN 61000-6-3:2007 + A1:2011; EN 50270:2015
ATEX	ATEX Directive 2014/34/UE EN IEC 60079-0:2018 EN 60079-1:2014 EN 60079-31:2014 EN60079-11:2012
IECEX	IEC 60079-0:2011 IEC 60079-1:2014 IEC 60079-31:2013 IEC 60079-11:2011
SIL	EN 61508:2010 Parti 1, 2, 3, 4, 5, 6, 7 EN50402:2017

Sensitron srl works for a constant improvement of its products and reserves the right to change the technical data without notice.

To have the updated product characteristics check on the website [www.sensitron.it](http://www.sensitron.it) or write an e-mail to [sales@sensitron.it](mailto:sales@sensitron.it)

Sensitron srl, Viale della Repubblica 48, Cornaredo (MI) - 20007

sales@sensitron.it

TEL. +39 0293548155 FAX. +39 0293548089

**Product codes****ATEX code**

S3004SD	SO <sub>2</sub> (0-20 ppm) gas detector	ST / 7W / EL1 / SI
S3008ND	NO <sub>2</sub> (0-20 ppm) gas detector	ST / 7W / EL1 / SI
S3012CL	CL <sub>2</sub> (0-5 ppm) gas detector	ST / 7W / EL1 / SI
S3014CL	CL <sub>2</sub> (0-20 ppm) gas detector	ST / 7W / EL1 / SI

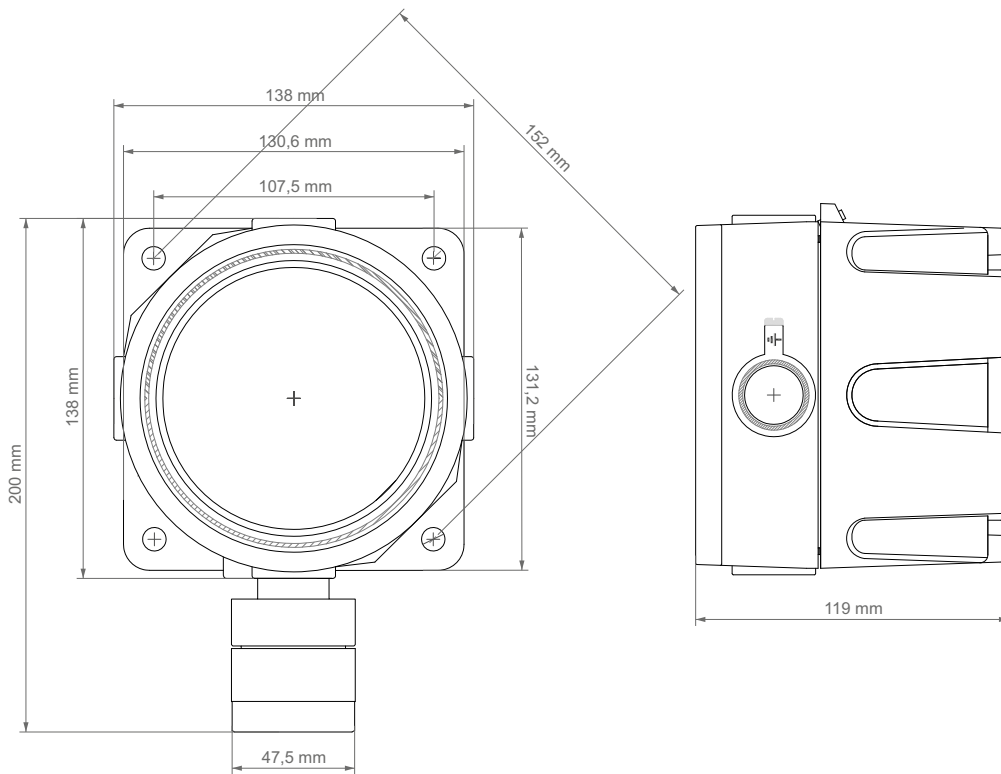
**Mechanical drawings**

STG/AD3  
Dust adapter

