

SMART3R

with catalytic sensor

SMART3R is developed to detect different gases in non classified areas, as machinery rooms and laboratories. A pellistor sensor is used to detect flammable gases, in order to get an optimal accuracy and selectivity. 4 smart LEDs illuminate the transparent ring to describe the detector status and an internal buzzer is activated in alarm and fault conditions. The SMART3R LITE gas detector has a standard 12-24 Vdc power supply, but a 220 Vac version can be supplied. The gas detector has three relay outputs, an RS485 serial communication and an analogue 4-20 mA output (not in 220 Vac version).

The polycarbonate case has a global size of 130 x 130 x 74 mm. The box has 2 entries with M20 cable glands. On the sides there are pre-formed guides that can be drilled to add up to 6 M16 cable glands.

The gas detector can be equipped with a remote head connected with a RJ12 6P6C cable.



Sensing element

Application	Machinery rooms, laboratories and non-classified areas
Sensing element	Catalytic
Predicted life sensor	4 / 5 years
Gas detected	Methane, LPG, Propane, Butane, Petrol Vapours
Fullscale	0 - 100% LFL

Electrical data

Power supply	12-24 Vdc or 90-240Vac
Signal output	3 relays; RS485 serial output, 4-20 mA analogue output (only for 12-24 Vdc version)
Dissipated power	73 mA at 24 Vdc
Relays contact rating	1.0 A at 30 Vdc
Optical indications	4 smart LED
Acoustic indications	Buzzer 63 dB
Hall effect sensor	-
Remote head cable	RJ12 6P6C

Environmental conditions

Storage temperature	-40 / +85°C
Operating temperature	-40 / +60°C
Operating humidity	0 / 95% RH non condensing

Mechanical drawings

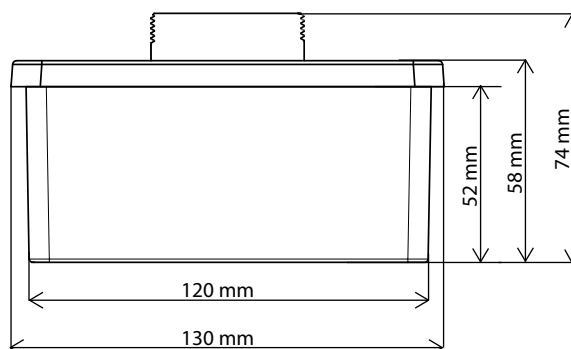
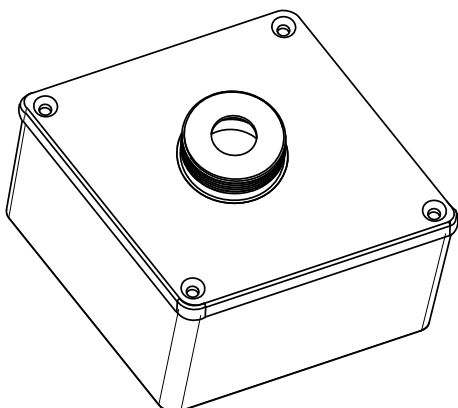

Product codes

S4590ME	Methane gas detector, 12-24 Vdc
S4590GP	LPG gas detector, 12-24 Vdc
S4590PR	Propane gas detector, 12-24 Vdc
S4590BU	Butane gas detector, 12-24 Vdc
S4590VB	Petrol vapours gas detector, 12-24 Vdc

Add "-220" to get the 220 Vac version

Add "-RH" to get the version with remote head

Add "-220-RH" to get the 220 Vac version with remote head

External case

Material	Polycarbonate
Dimensions	Box: 120 x 120 x 52 mm Cover: 130 x 130 x 22 mm Remote head box: 106 x 106 x 56 mm Maximum length of remote head's cable: 5 m
Weight	Detector: 450 g Remote head: 300 g
Cable entry	2 entries with M20 cable glands 6 optional entries for M16 cable glands
IP Grade	IP42

Compliance

EMC	EN 61000-6-3:2007 + A1:201; EN 50270:2015
Refrigeration Standards	EN 378-3; EN 14624; EN 50676; IEC 60335-2-40 Annex LL; ISO 5149-3; F-Gas Regulation

Sensitron srl works for a constant improvement of its products and reserves the right to change the technical data without notice.

To have the updated product characteristics check on the website www.sensitron.it or write an e-mail to sales@sensitron.it

Sensitron srl, Viale della Repubblica 48, Cornaredo (MI) - 20007

sales@sensitron.it

TEL. +39 0293548155 FAX. +39 0293548089