

# SMART3R

with electrochemical cell

SMART3R is developed to detect different gases in non classified areas, as machinery rooms and laboratories. An electrochemical cell is used to detect toxic gases, due to the optimal performance in these applications. 4 smart LEDs illuminate the transparent ring to describe the detector status and an internal buzzer is activated in alarm and fault conditions. The SMART3R LITE gas detector has a standard 12-24 Vdc power supply, but a 220 Vac version can be supplied. The gas detector has three relay outputs, an RS485 serial communication and an analogue 4-20 mA output (not in 220 Vac version).

The polycarbonate case has a global size of 130 x 130 x 74 mm. The box has 2 entries with M20 cable glands. On the sides there are pre-formed guides that can be drilled to add up to 6 M16 cable glands.

The gas detector can be equipped with a remote head connected with a RJ12 6P6C cable.



## Sensor

Application	Machinery rooms, laboratories and non-classified areas
Sensing element	Electrochemical cell
Predicted life sensor	2 / 3 years
Gas detected	O <sub>2</sub> [0-25% Vol], CO [0-500 ppm], SO <sub>2</sub> [0-20 ppm], NH <sub>3</sub> [0-100/200/1000 ppm], Cl <sub>2</sub> [0-20 ppm], H <sub>2</sub> S [0-50 ppm], , NO <sub>2</sub> [0 - 20 ppm]

## Electrical data

Power supply	12-24 Vdc or 90-240Vac
Signal output	3 relays; RS485 serial output, 4-20 mA analogue output (only for 12-24 Vdc version)
Dissipated power	60 mA at 24Vdc
Relays contact rating	1.0 A at 30 Vdc
Optical indications	4 smart LED
Acoustic indications	Buzzer 63 dB
Hall effect sensor	-
Remote head cable	RJ12 6P6C

## Environmental conditions

Storage temperature	0 / +20°C up to 6 months
Operating temperature	-30 / +50°C
Operating humidity	15 / 90% RH non condensing

## Mechanical drawings

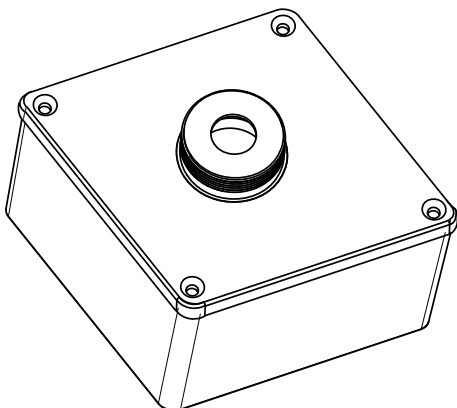

## Product codes

S4593O2	Oxygen gas detector (0 - 25% Vol), 12-24 Vdc
S4595CO	Carbon monoxide gas detector (0 - 500 ppm), 12-24 Vdc
S4597AM	Ammonia gas detector (0 - 100 ppm), 12-24 Vdc
S4598AM	Ammonia gas detector (0 - 200 ppm), 12-24 Vdc
S4599AM	Ammonia gas detector (0 - 1000 ppm), 12-24 Vdc
S4634CL	Chlorine gas detector (0 - 20 ppm), 12-24 Vdc
S4601HS	Hydrogene sulphide gas detector (0 - 50 ppm), 12-24 Vdc
S4630SD	Sulphur dioxide gas detector (0 - 20 ppm), 12-24 Vdc
S4632ND	Nitrogen dioxide detector(0 - 20 ppm), 12-24 Vdc

Add "-220" to get the 220 Vac version  
 Add "-RH" to get the version with remote head  
 Add "-220-RH" to get the 220 Vac version with remote head

## External case

Material	Polycarbonate
Dimensions	Box: 120 x 120 x 52 mm Cover: 130 x 130 x 22 mm Remote head box: 106 x 106 x 56 mm Maximum length of remote head's cable: 5 m
Weight	Detector: 450 g Remote head: 300 g
Cable entry	2 entries with M20 cable glands 6 optional entries for M16 cable glands
IP Grade	IP42

## Compliance

EMC	EN 61000-6-3:2007 + A1:201; EN 50270:2015
Refrigeration Standards	EN 378-3; EN 14624; EN 50676; IEC 60335-2-40 Annex LL; ISO 5149-3; F-Gas Regulation

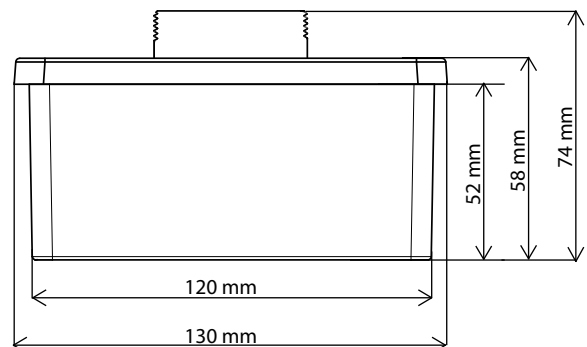

Sensitron srl works for a constant improvement of its products and reserves the right to change the technical data without notice.

To have the updated product characteristics check on the website [www.sensitron.it](http://www.sensitron.it) or write an e-mail to [sales@sensitron.it](mailto:sales@sensitron.it)

Sensitron srl, Viale della Repubblica 48, Cornaredo (MI) - 20007

sales@sensitron.it

TEL. +39 0293548155 FAX. +39 0293548089