

SMART3R LITE

SMART3R LITE is developed to detect refrigerant gases and carbon dioxide in machinery rooms and refrigeration plants. The design is aimed to have a cost-effective product, thanks also to the use of a special infrared sensor housed in the front ring. Smart LEDs illuminate the transparent ring to describe the detector status and an internal buzzer is activated in alarm and fault conditions. The SMART3R LITE gas detector has a 12-24 Vdc power supply and has two relay outputs. Optionally, a plug-in RS485 board enable the serial communication. The polycarbonate case has a global size of 130 x 130 x 74 mm. The box has 2 entries with M20 cable glands. On the sides there are pre-formed guides that can be drilled to add up to 6 M16 cable glands.

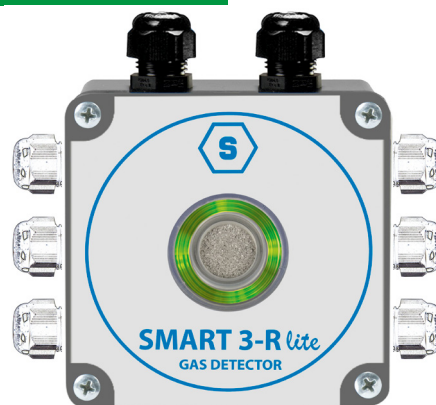

Sensore

Application	Machinery rooms and refrigeration plants
Sensing element	Infrared
Predicted sensor life	>5 years
Gas detected	R32, R1234YF, R1234ZE, R454A, R454B, R454C, R452B, R134A, R410A, R404A, R407C, CO ₂
Fullscale	0-20% LFL 0-5000 ppm
Alarm thresholds	5 e 10% LFL 1000 e 2000 ppm

Electrical data

Power supply	12-24 Vdc
Signal output	2 relays; RS485 serial output (optional)
Dissipated power	65 mA at 24 Vdc
Relays contact rating	1.0 A at 30 Vdc
Optical indications	7 LED (2 green, 3 red e 2 yellow)
Acoustic indications	Buzzer 63 dB
Hall effect sensor	-

Product P/N

S3832R32	R32 detector, thresholds 5% and 10% LFL, 12-24 Vdc
S3833R1234YF	R1234YF detector, thresholds 5% and 10% LFL, 12-24 Vdc
S3834R1234ZE	R1234ZE detector, thresholds 5% and 10% LFL, 12-24 Vdc
S3860R454A	R454A detector, thresholds 5% and 10% LFL, 12-24 Vdc
S3861R454B	R454B detector, thresholds 5% and 10% LFL, 12-24 Vdc
S3862R454C	R454C detector, thresholds 5% and 10% LFL, 12-24 Vdc
S3863R452B	R452B detector, thresholds 5% and 10% LFL, 12-24 Vdc
S3835R134A	R134A detector, thresholds 1000 and 2000 ppm, 12-24 Vdc
S3836R410A	R410A detector, thresholds 1000 and 2000 ppm, 12-24 Vdc
S3837R32	R32 detector, thresholds 1000 and 2000 ppm, 12-24 Vdc
S3838R404A	R404A detector, thresholds 1000 and 2000 ppm, 12-24 Vdc
S3839R407C	R407C detector, thresholds 1000 and 2000 ppm, 12-24 Vdc
S3840R1234YF	R1234YF detector, thresholds 1000 and 2000 ppm, 12-24 Vdc
S3841R1234ZE	R1234ZE detector, thresholds 1000 and 2000 ppm, 12-24 Vdc
S3842CO2	CO ₂ detector, thresholds 1000 and 2000 ppm, 12-24 Vdc

External case

Material	Polycarbonate
Dimensions	Box: 120 x 120 x 52 mm Cover: 130 x 130 x 22 mm
Weight	450 g
Cable entries	2 entries with M20 cable glands 6 optional entries for M16 cable glands
IP grade	IP42

Environmental conditions

Storage temperature	-40 / +85°C
Operating temperature	-10 / +50°C
operating humidity	0 / 95% RH non condensing

Compliance

EMC	EN 61000-6-3:2007 + A1:2011; EN 50270:2015
Refrigeration Standards	EN 378-3; EN 14624; EN 50676; IEC 60335-2-40 Annex LL; ISO 5149-3; F-Gas Regulation

Mechanical drawings

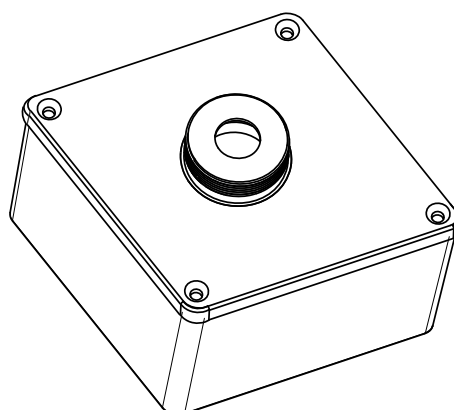
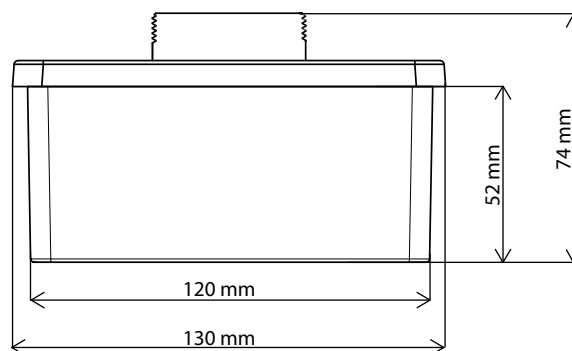

Sensitron srl works for a constant improvement of its products and reserves the right to change the technical data without notice.

To have the updated product characteristics check on the website www.sensitron.it or write an e-mail to sales@sensitron.it

Sensitron srl, Viale della Repubblica 48, Cornaredo (MI) - 20007
sales@sensitron.it

TEL. +39 0293548155 FAX. +39 0293548089